



ORION 2



Leva unica per chiusura generale, parziale (2 vie) e scarico. Valvola regolazione a pressione costante. Costruzione interamente in ottone.

One total and partial shut off lever (2 outlets). Constant pressure regulation valve. Body of brass.

Levier unique pour fermeture Générale et partielle (2 voies). Régulateur à pression constante. Corps en laiton.

Palanca unica para cerrado general y parcial (2 vias). Válvula reguladora a presión constante. Construido en bronce.

Einzigiger Hebel für generelle und teilweise Schließung. Gleichdruckeinstellventil. Aus hochwertigem.

Gruppo comando alta pressione
High pressure control assemblies
Regulateurs haute pression
Grupos de mando alta presión
Hochdruck-reglern

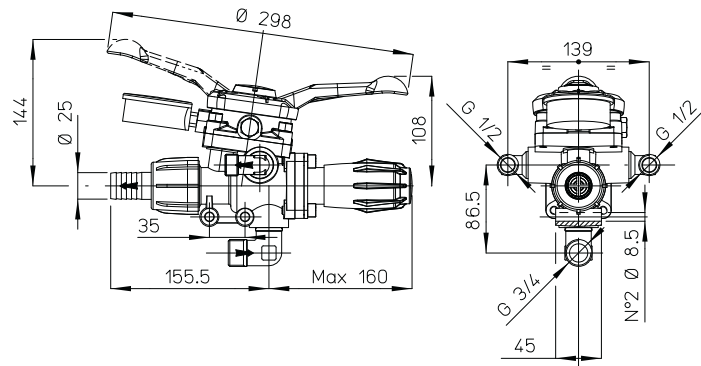

Tipo Type Type Tipo Typ	Pompe Pumps Pompes Bombas Pumpen	Pressione max Max pressure Pression max Presión max Max Druck	Portata max Max delivery Débit max Caudal max Max Leistung	Rubinetti Taps Robinets Grifos Hähne	Peso Weight Poids Peso Gewicht
		bar p.s.i.	l/min U.S. g.p.m.	n.	Kg lb
● 40	APS 51 - APS 61 APS 71-96 - 101 121-145-141-166	40 580	180 47,6	2	4,2 9,2
● 50	IDS 960 - 1000 1300 - 1400 - 1201 1401-1501-1701-2001 YA 65 - 75-130 -150 YB 150	50 725	180 47,6	2	4,2 9,2

ORION 2

GRV 2/4V



Leva chiusura generale. Risucchio antigoccia. Valvola regolazione volumetrica con valvola di massima pressione incorporata. Costruzione in alluminio anodizzato anticorrosione. 2/4 vie.

General shut off lever. Antidrip suck-back device. Proportional regulation valve with built in max pressure valve. Body of anti-corrosion anodized aluminium. 2/4 outlets.

Levier fermeture générale. Réaspiration anti-goutte. Régulateur D.P.M. avec soupape de pression maximale incorporée. Corps en aluminium anodisé anticorrosion. 2/4 voies.

Palanca cierre general. Retorno antigoteo. Válvula reguladora volumétrica con válvula de máxima presión incorporada. Construido en aluminio anodizado anticorrosivo. 2/4 salidas.

Genereller Absperrhebel. Anti-Tropf-Rücksaugung. Volumetrisches Einstellventil mit eingebautem Höchstdruckventil. Aus korrosionsfestem eloxiertem Aluminium gebaut. 2/4 wege.

Gruppo comando alta pressione
High pressure control assemblies
Regulateurs haute pression
Grupos de mando alta presión
Hochdruck-reglern

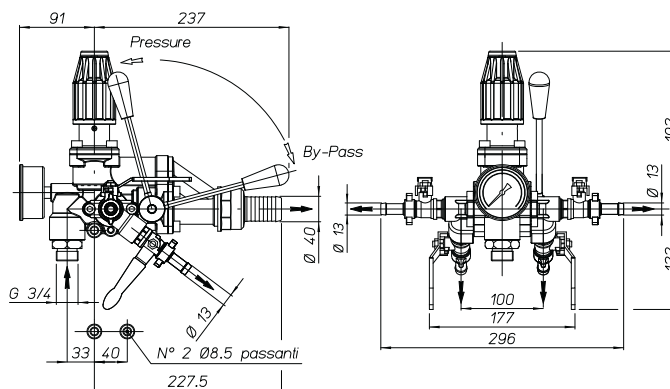

Pompe Pumps Pompes Bombas Pumpen	Pressione max Max pressure Pression max Presión max Max Druck	Portata max Max delivery Débit max Caudal max Max Leistung	Rubinetti Taps Robinets Grifos Hähne	Peso Weight Poids Peso Gewicht
	bar p.s.i.	l/min U.S. g.p.m.	n.	Kg lb
BP 171 K-205 K 235 K - 280 K - 241 281 -251 HS 291 HS	20 290	240 63,4	4	3,2 7
IDS 1400-1201 1401-1501-1701 2001-2000-2200 2600 APS 145-141-166	50 725	240 63,4	2/4	3,2 7

GRV 2/4V